

### Applications

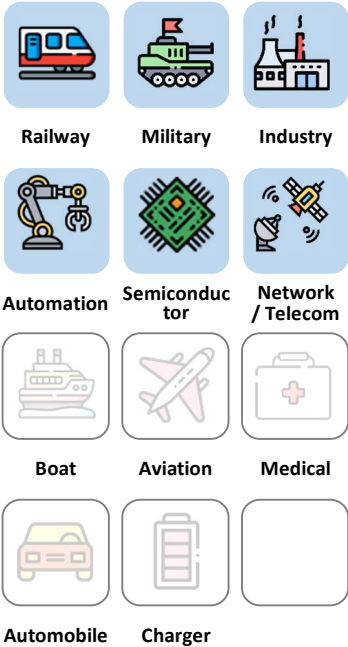

**3** Years Warranty



### Features

1.6" x 1"	2:1 / 4:1 Wide input range	+70°C without derating	EMC FILTER Built-in	2250 VDC Insulation	MLCC No life-span constrained	ON / OFF REMOTE	91 % High efficiency
MTBF ≥2.1M hours @50°C GB	METAL CASE	UVLO	OCP	OVP	OTP		

### Model Number Structure

**ESB 018 033 - S - P - F 30**

Series Name	Input Voltage (VDC)	Output Voltage (VDC)	Output Quantity	Remote Control Option	Shape	Watt
Evolving Sirius- Bishop series –	012 : 9-18 018 : 9-36 024 : 18-36 036 : 18-75 048 : 36-75	033 : 3.3	S : Single	P : Positive logic N : Negative logic	F : Flat P : Groove Cover	15 20 25 30
		050 : 5				
		120 : 12				
		150 : 15				
	024 : 18-36 036 : 18-75 048 : 36-75	240 : 24	D : Dual	1 : Positive logic + EMC Filter 0 : Negative logic + EMC Filter		
		050 : ±5				
		120 : ±12				
		150 : ±15				
		240 : ±24				

**Model Selection Guide**

Typical @ Ta=+25 °C under nominal line voltage conditions unless noted

Model	Input			Output			Efficiency
	Voltage (V)		Current (A)	Voltage	Current	Power	
	Range	Nominal	Full load	(V)	(A)	(W)	Typ.(%)
ESB012033-S-□-□15	9-18	12	1.40	3.3	4.5	15	89%
ESB012050-S-□-□15	9-18	12	1.39	5	3	15	90%
ESB012120-S-□-□15	9-18	12	1.42	12	1.3	15	88%
ESB012150-S-□-□15	9-18	12	1.42	15	1	15	88%
ESB012240-S-□-□15	9-18	12	1.42	24	0.7	15	88%
ESB012120-D-□-□15	9-18	12	1.42	±12	±0.63	15	88%
ESB012150-D-□-□15	9-18	12	1.42	±15	±0.5	15	88%
ESB012240-D-□-□15	9-18	12	1.42	±24	±0.3	15	88%
ESB012033-S-□-□20	9-18	12	1.87	3.3	6	20	89%
ESB012050-S-□-□20	9-18	12	1.85	5	4	20	90%
ESB012120-S-□-□20	9-18	12	1.89	12	1.7	20	88%
ESB012150-S-□-□20	9-18	12	1.89	15	1.3	20	88%
ESB012240-S-□-□20	9-18	12	1.89	24	0.8	20	88%
ESB012120-D-□-□20	9-18	12	1.89	±12	±0.8	20	88%
ESB012150-D-□-□20	9-18	12	1.89	±15	±0.7	20	88%
ESB012240-D-□-□20	9-18	12	1.89	±24	±0.4	20	88%
ESB018033-S-□-□15	9-36	18	0.95	3.3	4.5	15	88%
ESB018050-S-□-□15	9-36	18	0.94	5	3	15	89%
ESB018120-S-□-□15	9-36	18	0.95	12	1.3	15	88%
ESB018150-S-□-□15	9-36	18	0.95	15	1	15	88%
ESB018240-S-□-□15	9-36	18	0.95	24	0.7	15	88%
ESB018120-D-□-□15	9-36	18	0.95	±12	±0.7	15	88%
ESB018150-D-□-□15	9-36	18	0.95	±15	±0.5	15	88%
ESB018240-D-□-□15	9-36	18	0.96	±24	±0.3	15	87%
ESB018033-S-□-□20	9-36	18	1.26	3.3	6	20	88%
ESB018050-S-□-□20	9-36	18	1.25	5	4	20	89%
ESB018120-S-□-□20	9-36	18	1.26	12	1.7	20	88%
ESB018150-S-□-□20	9-36	18	1.26	15	1.3	20	88%
ESB018240-S-□-□20	9-36	18	1.26	24	0.8	20	88%
ESB018120-D-□-□20	9-36	18	1.26	±12	±0.8	20	88%
ESB018150-D-□-□20	9-36	18	1.26	±15	±0.7	20	88%
ESB018240-D-□-□20	9-36	18	1.28	±24	±0.4	20	87%

Model	Input			Output			Efficiency
	Voltage (V)		Current (A)	Voltage	Current	Power	
	Range	Nominal	Full load	(V)	(A)	(W)	Typ.(%)
ESB018033-S-□-□25	9-36	18	1.60	3.3	7.6	25	87%
ESB018050-S-□-□25	9-36	18	1.56	5	5	25	89%
ESB018120-S-□-□25	9-36	18	1.58	12	2.1	25	88%
ESB018150-S-□-□25	9-36	18	1.58	15	1.7	25	88%
ESB018240-S-□-□25	9-36	18	1.58	24	1	25	88%
ESB018120-D-□-□25	9-36	18	1.58	±12	±1.0	25	88%
ESB018150-D-□-□25	9-36	18	1.58	±15	±0.8	25	88%
ESB018240-D-□-□25	9-36	18	1.60	±24	±0.5	25	87%
ESB024033-S-□-□15	18-36	24	0.70	3.3	4.5	15	89%
ESB024050-S-□-□15	18-36	24	0.69	5	3	15	90%
ESB024120-S-□-□15	18-36	24	0.70	12	1.3	15	89%
ESB024150-S-□-□15	18-36	24	0.70	15	1	15	89%
ESB024240-S-□-□15	18-36	24	0.70	24	0.7	15	89%
ESB024120-D-□-□15	18-36	24	0.70	±12	±0.7	15	89%
ESB024150-D-□-□15	18-36	24	0.70	±15	±0.5	15	89%
ESB024240-D-□-□15	18-36	24	0.70	±24	±0.3	15	89%
ESB024033-S-□-□20	18-36	24	0.95	3.3	6	20	88%
ESB024050-S-□-□20	18-36	24	0.94	5	4	20	89%
ESB024120-S-□-□20	18-36	24	0.94	12	1.7	20	89%
ESB024150-S-□-□20	18-36	24	0.94	15	1.3	20	89%
ESB024240-S-□-□20	18-36	24	0.94	24	0.8	20	89%
ESB024120-D-□-□20	18-36	24	0.94	±12	±0.8	20	89%
ESB024150-D-□-□20	18-36	24	0.94	±15	±0.7	20	89%
ESB024240-D-□-□20	18-36	24	0.95	±24	±0.4	20	88%
ESB024033-S-□-□30	18-36	24	1.42	3.3	9.1	30	88%
ESB024050-S-□-□30	18-36	24	1.39	5	6	30	90%
ESB024120-S-□-□30	18-36	24	1.42	12	2.5	30	88%
ESB024150-S-□-□30	18-36	24	1.42	15	2	30	88%
ESB024240-S-□-□30	18-36	24	1.42	24	1.3	30	88%
ESB024120-D-□-□30	18-36	24	1.42	±12	±1.3	30	88%
ESB024150-D-□-□30	18-36	24	1.40	±15	±1.0	30	89%
ESB024240-D-□-□30	18-36	24	1.42	±24	±0.6	30	88%

Model	Input			Output			Efficiency
	Voltage (V)		Current (A)	Voltage	Current	Power	
	Range	Nominal	Full load	(V)	(A)	(W)	Typ.(%)
ESB036033-S-□-□15	18-75	36	0.48	3.3	4.5	15	87%
ESB036050-S-□-□15	18-75	36	0.47	5	3	15	89%
ESB036120-S-□-□15	18-75	36	0.47	12	1.3	15	88%
ESB036150-S-□-□15	18-75	36	0.47	15	1	15	88%
ESB036240-S-□-□15	18-75	36	0.47	24	0.7	15	88%
ESB036120-D-□-□15	18-75	36	0.47	±12	±0.7	15	88%
ESB036150-D-□-□15	18-75	36	0.47	±15	±0.5	15	88%
ESB036240-D-□-□15	18-75	36	0.48	±24	±0.3	15	87%
ESB036033-S-□-□20	18-75	36	0.64	3.3	6	20	87%
ESB036050-S-□-□20	18-75	36	0.62	5	4	20	89%
ESB036120-S-□-□20	18-75	36	0.63	12	1.7	20	88%
ESB036150-S-□-□20	18-75	36	0.63	15	1.3	20	88%
ESB036240-S-□-□20	18-75	36	0.63	24	0.8	20	88%
ESB036120-D-□-□20	18-75	36	0.63	±12	±0.8	20	88%
ESB036150-D-□-□20	18-75	36	0.63	±15	±0.7	20	88%
ESB036240-D-□-□20	18-75	36	0.64	±24	±0.4	20	87%
ESB048033-S-□-□15	36-75	48	0.35	3.3	4.5	15	89%
ESB048050-S-□-□15	36-75	48	0.35	5	3	15	90%
ESB048120-S-□-□15	36-75	48	0.36	12	1.3	15	88%
ESB048150-S-□-□15	36-75	48	0.36	15	1	15	88%
ESB048240-S-□-□15	36-75	48	0.35	24	0.7	15	89%
ESB048120-D-□-□15	36-75	48	0.35	±12	±0.7	15	89%
ESB048150-D-□-□15	36-75	48	0.35	±15	±0.5	15	90%
ESB048240-D-□-□15	36-75	48	0.35	±24	±0.3	15	89%
ESB048033-S-□-□20	36-75	48	0.46	3.3	6	20	90%
ESB048050-S-□-□20	36-75	48	0.46	5	4	20	91%
ESB048120-S-□-□20	36-75	48	0.46	12	1.7	20	90%
ESB048150-S-□-□20	36-75	48	0.46	15	1.3	20	90%
ESB048240-S-□-□20	36-75	48	0.47	24	0.8	20	89%
ESB048120-D-□-□20	36-75	48	0.46	±12	±0.8	20	91%
ESB048150-D-□-□20	36-75	48	0.46	±15	±0.7	20	91%
ESB048240-D-□-□20	36-75	48	0.47	±24	±0.4	20	89%

Model	Input			Output			Efficiency
	Voltage (V)		Current (A)	Voltage	Current	Power	
	Range	Nominal	Full load	(V)	(A)	(W)	Typ.(%)
ESB048050-S-□-□30	36-75	48	0.69	5	6	30	90%
ESB048120-S-□-□30	36-75	48	0.70	12	2.5	30	89%
ESB048150-S-□-□30	36-75	48	0.70	15	2	30	89%

## Description

**Evolving Sirius - Bishop series converter** is composed of Isolated, board-mountable, fixed switching frequency dc-dc converters that use synchronous rectification to achieve extremely high power conversion efficiency. These DC-DC converter modules use advanced power processing, control, and packaging technologies to enhance the performance, flexibility, reliability, and cost effectiveness of mature power components. Each module is six-sided metal case enclosed to provide protection from the harsh environments seen in many industrial and transportation applications.

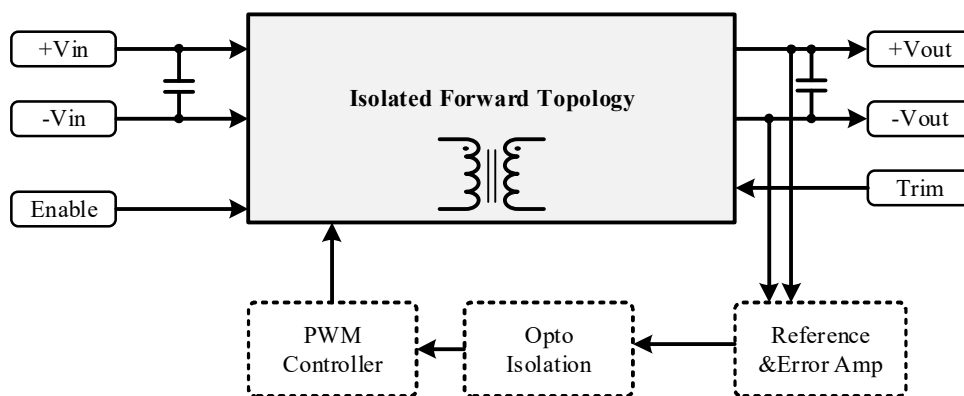

ESB Single Series Block Diagram

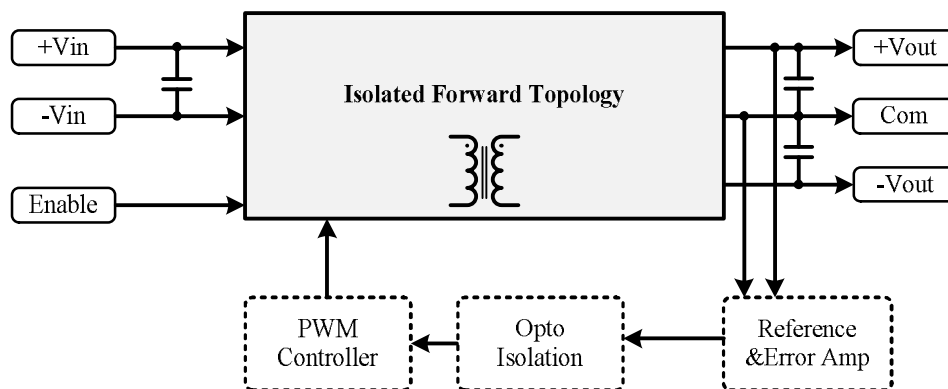

ESB Dual Series Block Diagram

**Electrical Specifications**

(Typical @ Ta=+25°C under nominal line voltage conditions unless noted.)

**Input Specifications**

Parameter	Notes and Conditions	Min.	Typ.	Max.	Unit
Transient Input Voltage Ranges	ESB012 models (100ms max)			50	VDC
	ESB018 models (100ms max)			50	
	ESB024 models (100ms max)			50	
	ESB036 models (100ms max)			80	
	ESB048 models (100ms max)			80	
Operating Input Voltage Ranges	ESB012 models	9	12	18	VDC
	ESB018 models	9	18	36	
	ESB024 models	18	24	36	
	ESB036 models	18	36	75	
	ESB048 models	36	48	75	
Under-Voltage Lockout Start up Voltage	ESB012 models		8.5	9	VDC
	ESB018 models		8.5	9	
	ESB024 models		17.5	18	
	ESB036 models		17.5	18	
	ESB048 models		35	36	
Under-Voltage Lockout Shutdown Voltage	ESB012 models	7	8		VDC
	ESB018 models	7	8		
	ESB024 models	16	17		
	ESB036 models	16	17		
	ESB048 models	32	34		
Enable Function Input	Positive logic	ON	Open or 4.5 ~ 5.5		VDC
		OFF	Short or 0 ~ 1.2		
	Negative logic	ON	Short or 0 ~ 1.2		VDC
		OFF	Open or 4.5 ~ 5.5		
Input Filter	All models	Built-in PI or EMC Filter			

**Output Specifications**

Parameter	Notes and Conditions	Min.	Typ.	Max.	Unit
Output Voltage Accuracy	V <sub>NOM</sub> 50% Load			±1.5	%
Line Regulation	Low Line to High Line			±0.3	%
Load Regulation	10% to 100% Load			±0.5	%
Minimum Load	Single output	0			%
	Dual output	10			%
Output Ripple & Noise Voltage	Bandwidth 20MHz and with 1µF MLCC Output Capacitor each output	3.3V & 5V		75/100	m Vp-p
		All others		1	1.5
Temperature Drift				±0.04	% / °C
Transient Recovery Time	25% load step change		800		µSec.
Transient Peak Deviation	ΔIo/Δt=2.5A/µs			±2	%Vo
Start-Up Time	When use Enable Function		20		mSec.
Trimming Output Voltage	V <sub>NOM</sub> 10% Load		±10		%
Over Voltage Protection	V <sub>NOM</sub> 10% Load		120		%
Output Power Protection	V <sub>NOM</sub> (Current limit)		120		%

**General Specifications & Environmental Specifications**

Parameter	Notes and Conditions	Min.	Typ.	Max.	Unit	
Switching Frequency	V <sub>NOM</sub>	2:1 wide	270	300	330	kHz
		4:1 wide	220	260	300	
Storage Temperature Range	All models	-55		125	°C	
Operating Case Temperature	All models	-45		115	°C	
Over temperature Protection	All models, Auto. Recovery		120			
Thermal impedance	Natural convection (Flat)	7.8 (Vertical) / 8.4 (horizontal)			°C/Watt	
	Natural convection (Groove Cover)	7.2 (Vertical) / 7.8 (horizontal)				
Isolation Voltage (Input to Output)	All models, 1 Minute	2250			VDC	
Isolation Resistance (Input to Output)	All models, 500VDC, At 70%RH	100			MΩ	
Isolation Capacitance (Input to Output)	All models		1500		pF	
Humidity (non condensing)	All models			95	%	
Calculated MTBF	BellCore-TR-332@ 50°C G.B		1.54		M HR	
Thermal shock	Environmental Engineering Experimental Tests	MIL-STD-810F				
Vibration		MIL-STD-810F				
Drop		MIL-STD-810F				
Weight	Shape-F (Flat)	24 (0.85)			g (oz.)	
	Shape-P (Groove Cover/ Heat Sink)	28 (1.0)				
Dimensions	Shape-F (Flat)	1.60" x 1.00" x 0.40" (40.6 x 25.4 x 10.2mm)				
	Shape-P (Groove Cover/ Heat Sink)	1.60" x 1.00" x 0.50" (40.6 x 25.4 x 12.7mm)				
Case Material	Six-Sided Continuous Shield	Aluminum				
Potting Material		Silicone				

**Standards Compliance**

Parameter	Standard	Test Conditions	Performance Criteria
Environmental Compliance	Reach; RoHS		PASS
EMI	EN55022		Class B
ESD	EN61000-4-2	±4 kV Air Discharge ±4 kV Contact Discharge	Crit. A
Radiated Immunity	EN61000-4-3	Level 2, 3 V/m	Crit. A
Fast Transient	EN61000-4-4	±2 kV Applied	Crit. A
Surge	EN61000-4-5	±2 kV Applied	Crit. A
Conducted Immunity	EN61000-4-6	Level 2, 3 V rms	Crit. A

It is recommended to protect the input by fuses or other protection devices.

**The standard modules meet EN55032 Class A and Class B standard with external components.**

The information and specifications contained in this data sheet are believed to be correct at time of publication. All specifications are subject to change without notice. No rights under any patent accompany the sale of any such products or information contained herein.

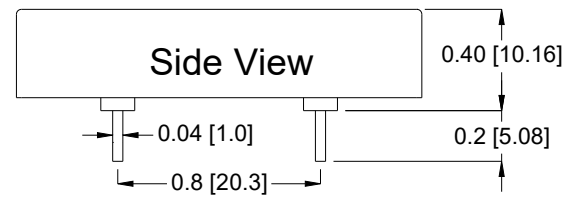
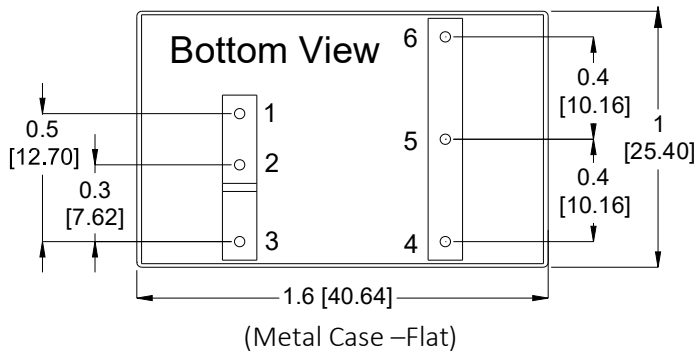
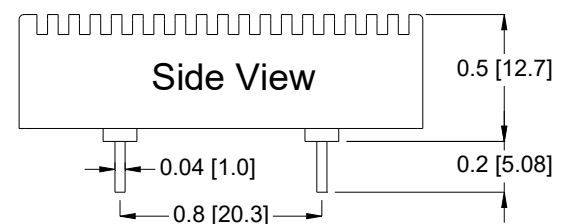
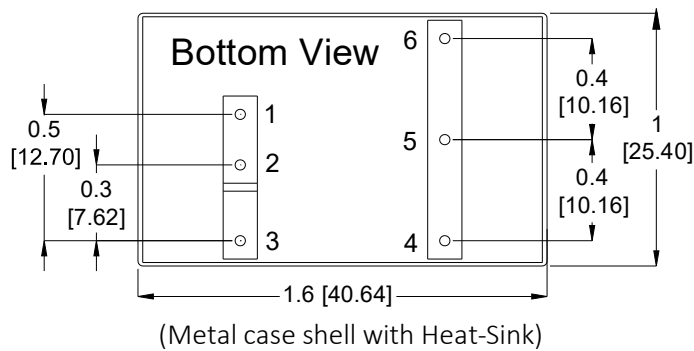
**Mechanical Dimensions & Pin Assignments**
**Shape – F**

**Shape – P (Groove Cover/Heat Sink)**

**Pin Assignments:**

Pin#	Single	Dual
1	+Vin	+Vin
2	-Vin	-Vin
3	Enable	Enable
4	-Vout	-Vout
5	Trim	Com
6	+Vout	+Vout

**Note:**

- Pin Pitch tolerance:  $\pm 0.01$  [0.25]
- Pin Dimensions:  $.XX \pm 0.02$  [  $.X \pm 0.5$ mm]
- Pin Material: Copper Alloy
- Pin Plating: Gold
- Dimensions in inches [mm]
- Tolerances:  $.XX \pm 0.02$  [  $.X \pm 0.5$ mm]
- $.XXX \pm 0.001$  [  $.X \pm 0.025$ mm]

**Conducted EMI**

Input terminal value (typ.) ESB036050-S-1-P20 @Vin = 36VDC, Iout = 4A

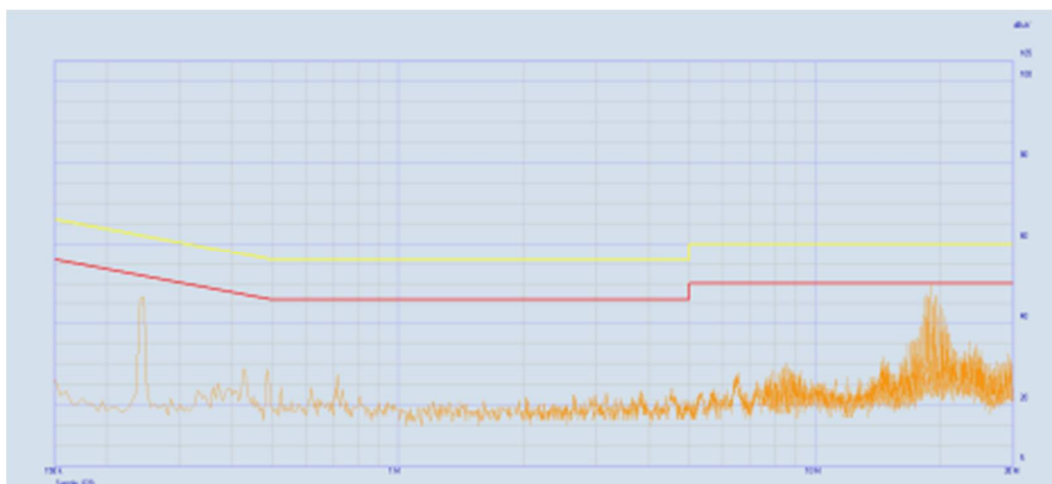

The fundamental switching frequency of the module is 260 kHz.



Characteristic Curves

Testing conditions are at typical input, Ta=+25°C, full load (horizontal mount) Unless otherwise indicated

The figures of ESB036050-S-1-P20

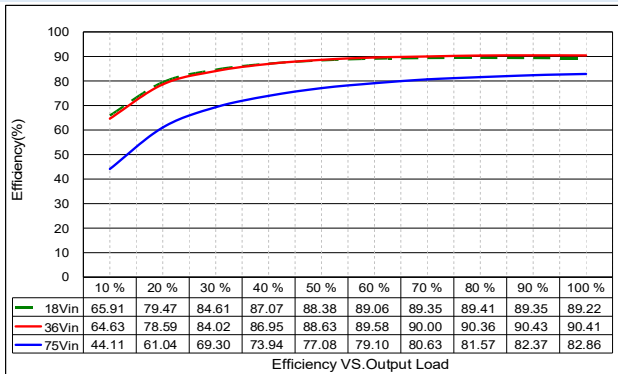

Figure 1 : Efficiency at Minimum, Nominal and Maximum Input voltages VS. Output load.

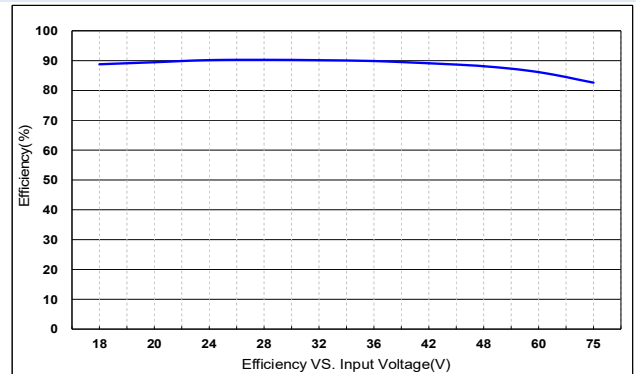

Figure 2 : Efficiency VS. Input Voltages at 100% rated power

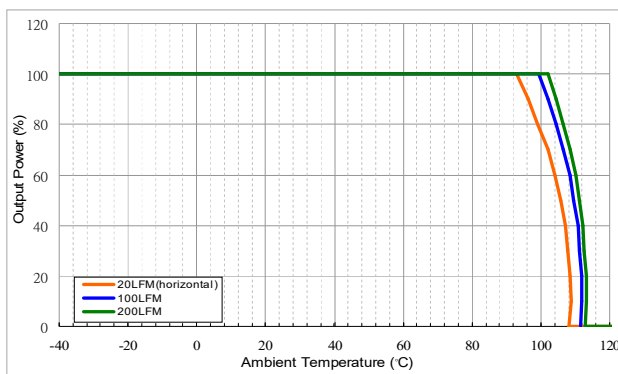

Figure 3 : Ambient Temperature VS. Output Power Derating Curves(Note: 20LFM = Free Air)

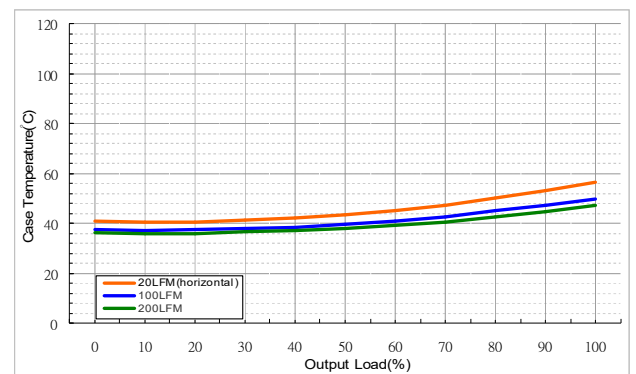

Figure 4 : Case Temperature VS. Output rated Power (Note: 20LFM = Free Air)

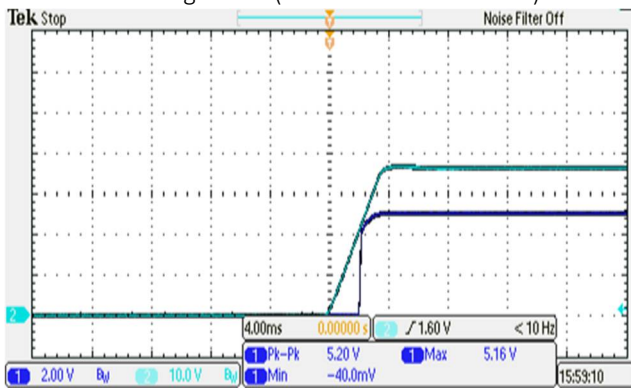

Figure 5 : CH1 = Vout, CH3 = Nominal Input Typical Start-up waveform at Full load.

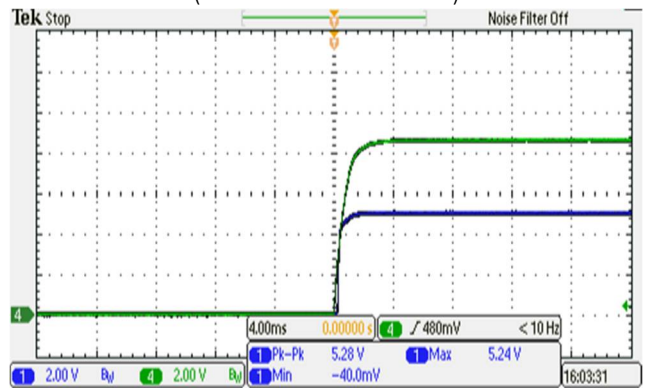

Figure 6 : CH1 = Vout, CH3 = Enable Pin

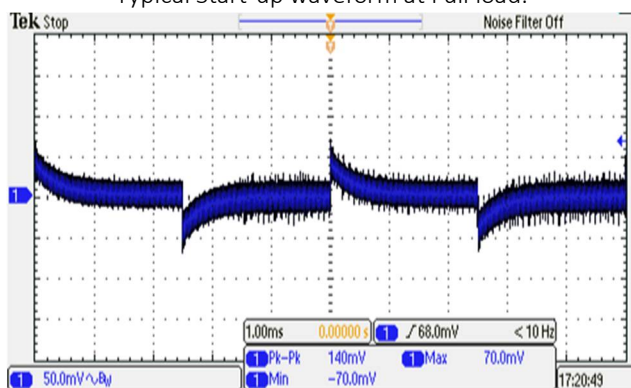

Figure 7 : Transient Response at Output step load ( Vin: Typical, 50~75% of output current;  $\Delta I_o/\Delta t = 1A/\mu S$  )

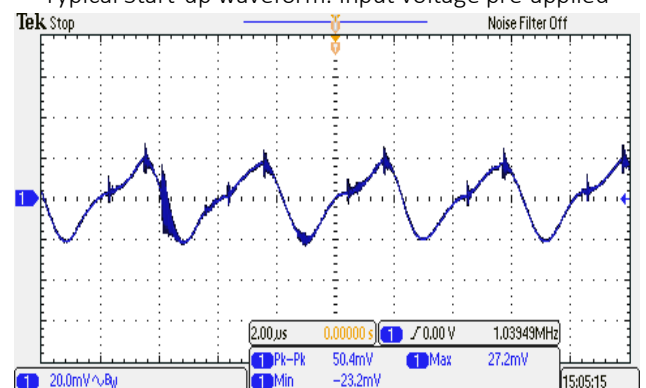

Figure 8 : Output Voltage Ripple & Noise at full load. ( Vin: Typical, With Output Capacitor to add 1uF MLCC )

**Trimming Output Voltage – for Single output models**

Only the single output converters have a trim function. That allows users to adjust the output voltage from +10% to -10%, please refer to the trim table that follow for details. Adjustments to the output voltage can be used with a simple fixed resistor as shown in Figures 1 and 2. A single fixed resistor can increase or decrease the output voltage depending on its connection.

**Note:**

- ✘ Trim adjustments higher than the specified range can have an adverse effect on the converter’s performance and are not recommended.
- ✘ If the trim function is not used, leave the trim pin open.

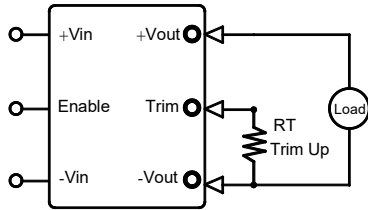

**Figure 1.** Trim Connections To increase Output Voltages Using Fixed Resistors

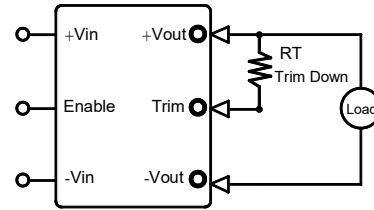

**Figure 2.** Trim Connections To decrease Output Voltages Using Fixed Resistors

Vout	Trim up resistor value(KΩ)									
	1%	2%	3%	4%	5%	6%	7%	8%	9%	10%
3.3	75	34	20.6	13.7	9.6	6.9	4.9	3.5	2.3	1.4
5	112.2	51.1	30.7	20.5	14.4	10.4	7.5	5.3	3.6	2.2
12	267.8	121.9	73.3	49.0	34.4	24.6	17.7	12.5	8.4	5.2
15	332.9	151.5	91	60.7	42.6	30.5	21.8	15.4	10.3	6.3
24	542	247	149	100	70.7	51.1	37.1	26.6	18.4	11.9

Vout	Trim down resistor value(KΩ)									
	-1%	-2%	-3%	-4%	-5%	-6%	-7%	-8%	-9%	-10%
3.3	83	37	21.9	14.3	9.7	6.7	4.5	2.9	1.6	0.6
5	139.8	63.5	38.1	25.4	17.8	12.7	9.0	6.3	4.2	2.5
12	342.5	155.9	93.7	62.6	44.0	31.5	22.7	16.0	10.8	6.7
15	454.5	205	125.8	84.7	60.1	43.6	31.9	23.1	16.2	10.7
24	592	266	158	104	70.9	49.2	33.7	22.1	13.0	5.8

**Enable Control Function**

The primary-side, Enable Control function can be specified to operate with either positive or negative polarity. Positive-polarity devices are enabled when the enable pin is left open or is pulled high. See “Enable Function Input.

Positive-polarity devices are disabled when the enable pin is pulled low (under +1.0V with respect to -input). Negative-polarity devices are off when the enable pin is high/open and on when the enable pin is pulled low. See Figure 4.

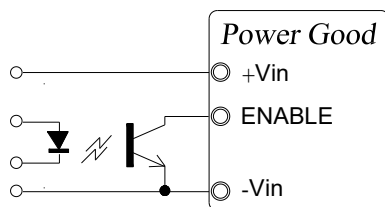

**Figure 4.** Driving the Enable Control pin

**Output Ripple Noise**

The two copper strips simulate real-world PCB impedances between the converter and its load. Scope measurements should be made using BNC connectors or the probe ground should be less than 1/2 inch and soldered directly to the fixture.

All external capacitors should have appropriate voltage ratings and be located as close to the converter as possible.

Temperature variations for all relevant parameters should be taken into consideration. The most effective combination of external I/O capacitors will be a function of line voltage and source impedance, as well as particular load and layout conditions. See Figure 5.

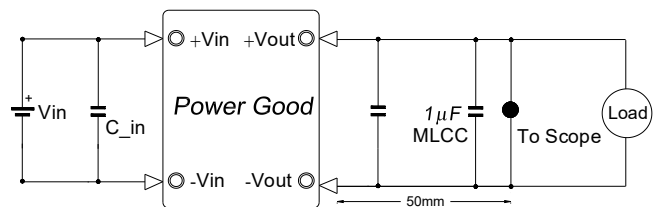

**Figure 5.** Measuring Output Ripple/Noise(20MHz bandwidth)



