

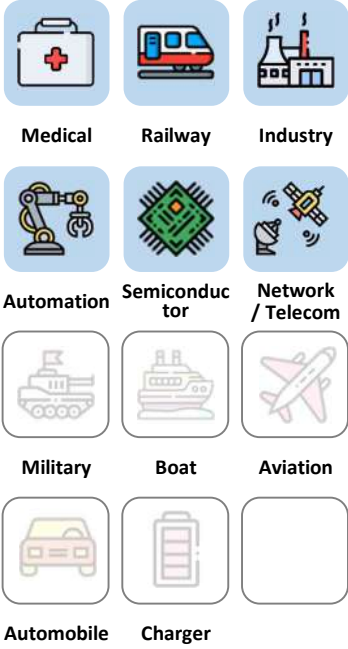

ACO100 Series

100W & 150W / Open Frame AC/DC

Applications



3 Years Warranty



Features

1/4 Brick	90~264VAC Input range	150W Active PFC	Long Hold-up Time	-40~100°C Case Temperature	±5% Output Trimming	3000 VAC Insulation	91% High efficiency
Base plate cooled	OCP	OVP	OTP	SCP			

Model Number Structure

AC	O	100	-	050	S	-	150
Series Name	Package	Watt		Output Voltage (VDC)	Output Quantity		Actual Watt
AC series	Open Frame	100		050 : 5 120 : 12 240 : 24 280 : 28 360 : 36 480 : 48	S : Single		Actual Watt

Model Selection Guide

Typical @ Ta=+25 °C under nominal line voltage conditions unless noted

Model	Input			Output			Efficiency
	Voltage (V)		Current (A)	Voltage	Current	Power	
	Range	Nominal	Full load	(V)	(A)	(W)	Typ.(%)
ACO100-120S-100	90-264	230	0.48	12	8.33	100	89
ACO100-240S-100	90-264	230	0.48	24	4.16	100	90
ACO100-280S-100	90-264	230	0.48	28	3.57	100	90
ACO100-360S-100	90-264	230	0.48	36	2.77	100	90
ACO100-480S-100	90-264	230	0.48	48	2.08	100	90
ACO100-120S-150	90-264	230	0.75	12	12.5	150	89
ACO100-240S-150	90-264	230	0.75	24	6.25	150	90
ACO100-280S-150	90-264	230	0.75	28	5.35	150	90
ACO100-360S-150	90-264	230	0.75	36	4.16	150	90
ACO100-480S-150	90-264	230	0.75	48	3.13	150	90

Description

AC series - Open Frame 100 converter is a 100W / 150W isolated, regulated ac/dc converter with active PFC in quarter brick package and long hold-up time setting by external capacitors. It features a high efficiency up to 90%, wide working case temperature range -40~+100°C, no minimum load required, 3kVac reinforced insulation, OVP, OCP, SCP, OTP, etc. These power modules use advanced power processing, control and packaging technologies and are suitable for many applications with harsh environments where wide temperature variation and space limitations, etc.

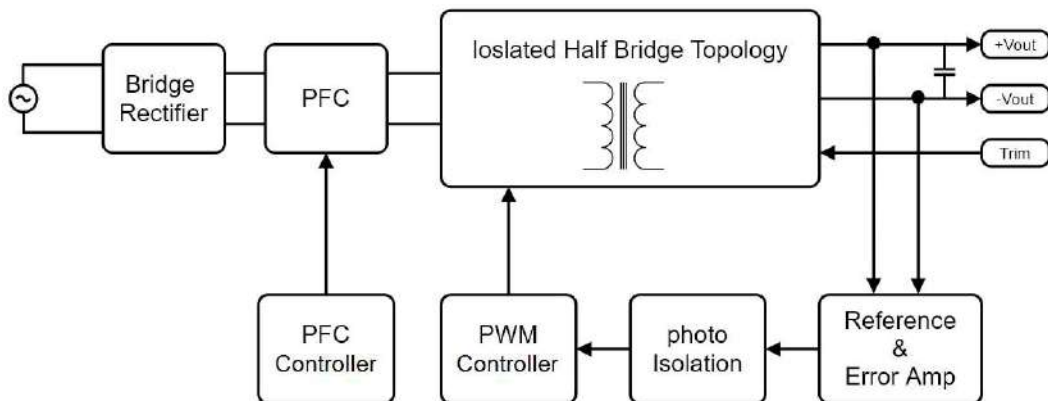

ACO100 Series Block Diagram

Electrical Specifications

(Typical @ Ta=+25° C under nominal line voltage conditions unless noted.)

Input Specifications

Parameter	Notes and Conditions	Min.	Typ.	Max.	Unit
Operating Input Voltage Ranges		90	230	264	VAC
Operating Input Frequency Ranges		47	50/60	63	Hz
Input Current	at 115VAC 100% load at 230VAC 100% load		1 0.5		A
Inrush Current	cold start at 230Vac, 25°C	Limited by external components (Thermistor)			
Power Factor	at 115VAC 100% load at 230VAC 100% load		1 0.99		
Leakage Current	at 240VAC 60Hz 100% load			0.75	mA

Output Specifications

Parameter	Notes and Conditions	Min.	Typ.	Max.	Unit
Output Voltage Accuracy	100% Load			±1.5	%
Line Regulation	High Line to Low Line			±0.5	%
Load Regulation	0% to 100% Load			±1	%
Output Ripple & Noise Voltage	Bandwidth 20MHz and with 10uF MLCC Output Capacitor			2	%V _{pk-pk}
Output Voltage Adjustment Range	adjustable by external resistor			±5	%
Minimum Load		0			A
Hold Up Time	at full load & 115 VAC	Setting by external capacitors between +BC & -BC			
Over Voltage Protection		110		140	%
Over current Protection	Hiccup mode		140		%
Short-circuit Protection	Hiccup mode	Auto-Recovery			

General Specifications & Environmental Specifications

Parameter	Notes and Conditions	Min.	Typ.	Max.	Unit
Switching Frequency	PFC/AC-DC		100/130		kHz
Storage Temperature Range	All models	-55		125	°C
Over temperature Protection	Auto Recovery		110		°C
Operating Case Temperature	on aluminum base plate	-40		100	°C
Humidity (non condensing)	All models			95	%
Isolation Voltage	Input to Output		3000		VAC
	Input to Base		1500		VAC
	Output to Base		500		VAC
Calculated MTBF	BellCore-TR-332@ 50°C G.B		1.2		M HR
Weight			260(9.17)		g (oz.)
Dimensions		5" x 1.64" x 1.0" (127 x 41.6 x 25.4mm)			
Case Material	Metal				

It is recommended to protect the input by fuses or other protection devices.

The information and specifications contained in this data sheet are believed to be correct at time of publication. All specifications are subject to change without notice. No rights under any patent accompany the sale of any such products or information contained herein.

Mechanical Dimensions & Pin Assignments

Shape

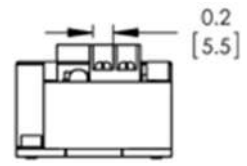
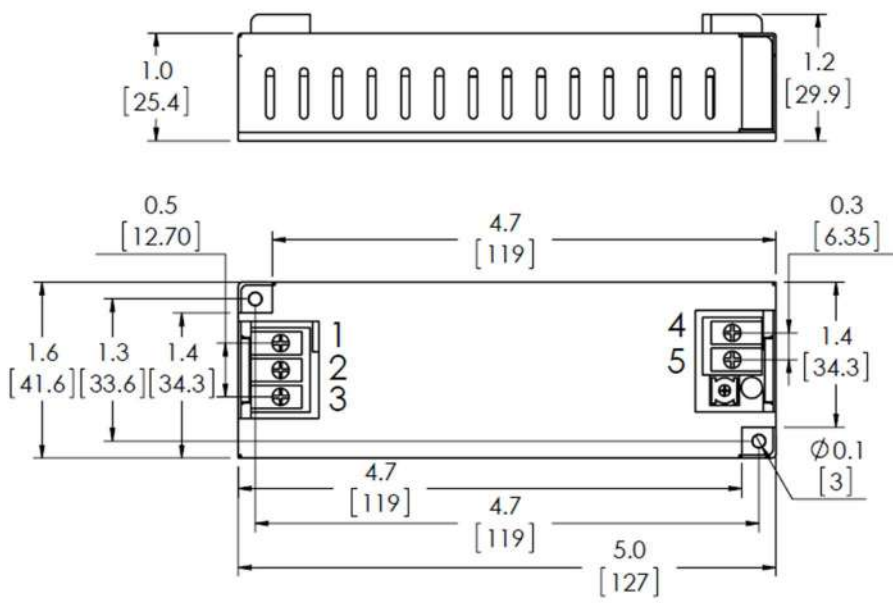

Pin Assignments:

Pin#	Function
1	ACL
2	ACN
3	FG
4	-VO
5	+VO

Note:
Pin Material: Copper Alloy
Pin Plating: Gold
Dimensions in inches [mm]
Tolerances: .XX±0.25 [.X±0.5mm]

Conducted EMI

Input terminal value (typ.) ACO100-120S-150 @Vin = 230VAC, Iout = 12.5A

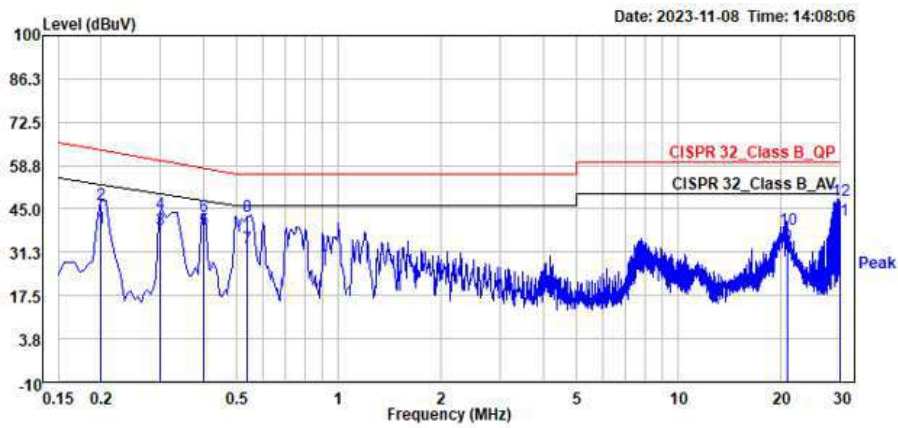

	Read	Limit	Over					
	Freq	Level	Factor	Level	Line	Limit	Pol/Phase	Remark
	MHz	dBuV	dB	dBuV	dBuV	dB		
1	0.201	28.63	10.27	38.90	52.82	-13.92	line1	Average
2	0.201	36.11	10.27	46.38	63.58	-17.20	line1	QP
3	0.300	28.43	10.26	38.69	49.82	-11.13	line1	Average
4	0.300	33.44	10.26	43.70	60.24	-16.54	line1	QP
5	0.400	28.20	10.27	38.47	47.67	-9.20	line1	Average
6	0.400	32.33	10.27	42.60	57.86	-15.26	line1	QP
7	0.536	22.31	10.28	32.59	46.00	-13.41	line1	Average
8	0.536	32.23	10.28	42.51	56.00	-13.49	line1	QP
9	20.948	21.52	12.03	33.55	50.00	-16.45	line1	Average
10	20.948	26.29	12.03	38.32	60.00	-21.68	line1	QP
11	PP 29.879	28.42	12.82	41.24	50.00	-8.76	line1	Average
12	QP 29.879	35.03	12.82	47.85	60.00	-12.15	line1	QP

The fundamental switching frequency of the module is 100 kHz.

