

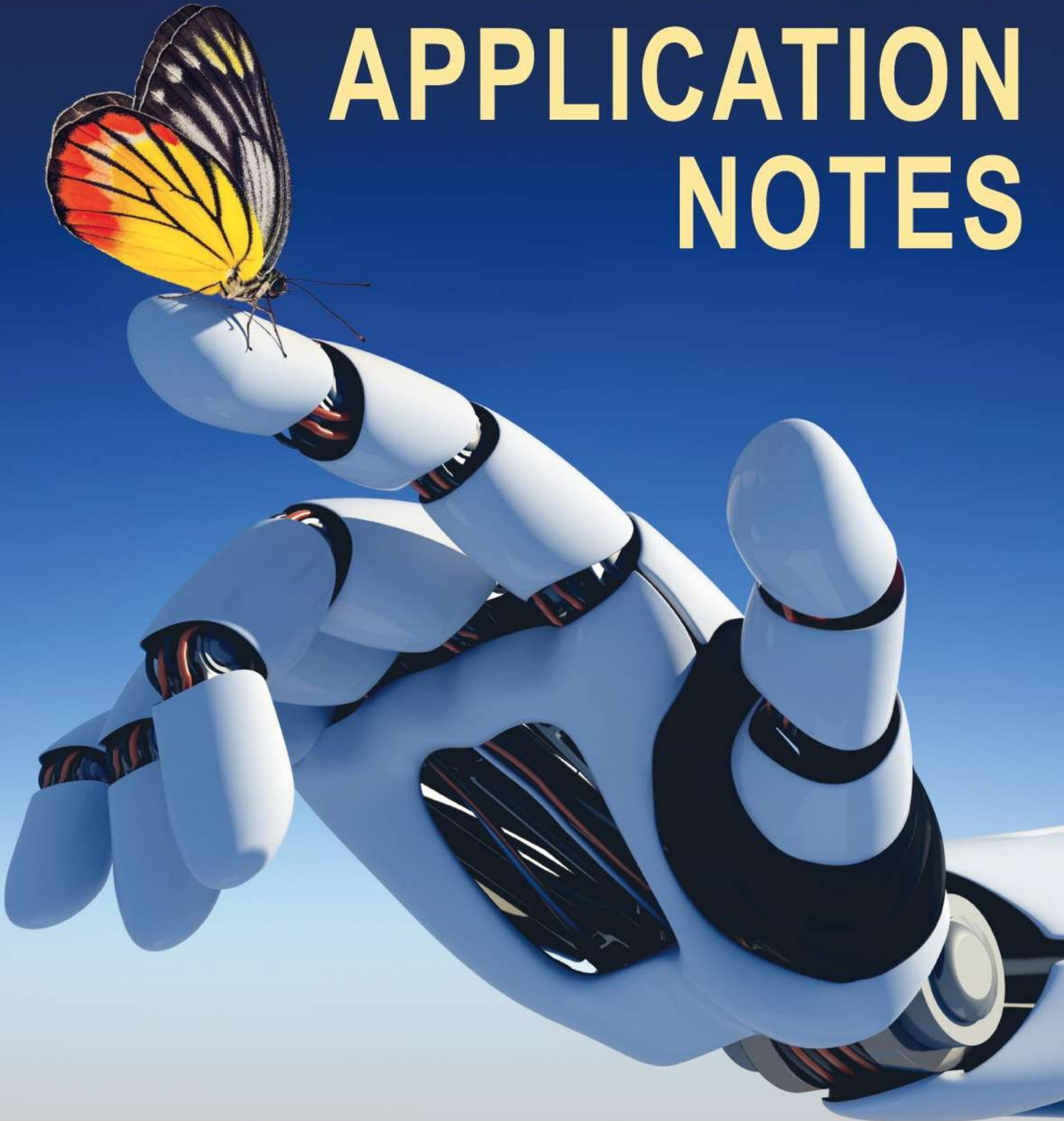

# AC DC Converters APPLICATION NOTES



**POWERGOOD Develops a Reliable Power Modules.**

## Absolute Maximum Rating

The Absolute Maximum Ratings indicate limits beyond which damage to the device may occur. The Operating Ratings indicate conditions for which the device is intended to be functional, but do not guarantee specific performance limits. For guaranteed specifications and test conditions, see the datasheets.

## Removal of Soldered AC/DC Modules from PCB's

Should removal of the Powergood AC/DC's module from its soldered connection be needed, it is very important to thoroughly de-solder the pins using solder wicks or de-soldering tools. At no time should any prying or leverage be used to remove boards that have not been properly de-soldered first.

## Output Ripple & Noise

In critical application, output ripple/noise can be reduced below specified limits using filtering techniques, the simplest of which is the installation of additional external output capacitors. Output capacitors function as true filter elements and should be selected for bulk capacitance, low ESR, and appropriate frequency response.

In Figure 1, the two copper strips simulate real-world PCB impedances between the converter and its load. Scope measurements should be made using BNC connectors or the probe ground should be less than 1/2 inch and soldered directly to the fixture.

All external capacitors should have appropriate voltage ratings and be located as close to the converter as possible. Temperature variations for all relevant parameters should be taken into consideration.

The most effective combination of external I/O capacitors will be a function of line voltage and source impedance, as well as particular load and layout conditions.

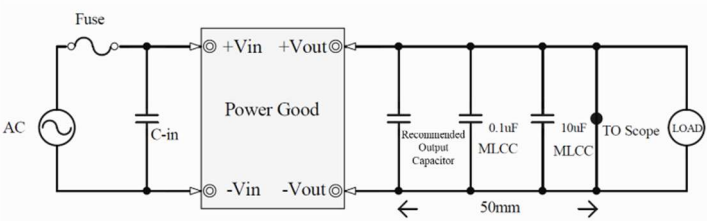

**Figure 1. Measuring Output Ripple/Noise (20MHz bandwidth)**

## Start-Up Time

There are two Start-Up Times. The first, Input to Output Start-Up Time is the interval between the point at which a ramping input voltage crosses the Start-Up Threshold voltage and the point at which the fully loaded output voltage enters and remains within its specified  $\pm 1\%$  accuracy band. Actual measured times will vary with input source impedance, external input capacitance, and the slew rate and final value of the input voltage as it appears to the converter. The second, Enable to Output Start-Up Time assumes the converter is turned off via the Enable control with the nominal input voltage already applied. The specification defines the interval between the point at which the converter is turned on and the point at which the fully loaded output voltage enters and remains within its specified  $\pm 1\%$  accuracy band.

## Input Fusing

Certain applications and/or safety agencies may require the installation of fuses at the inputs of power conversion components. Fuses should also be used if the possibility of a sustained, non-current limited exists. Generally, using a slow blow fuse with 200% approx. of the max. input current, See every datasheet for input current.

## Short Circuit Condition

When a converter is in current limit mode the output voltages will drop as the output current demand continuously increases to excess the pre-setting point then controller will shut down the converter. Following a timeout period of 10 to 20 milliseconds. The converter will restart and build up the output voltages to their appropriate values. If the short circuit condition persists, another shutdown cycle will be initiated. This on/off cycling is referred to as "hiccup" mode. The hiccup cycling reduces the average output current, thereby preventing internal temperatures from rising to excessive levels. The converter is capable of enduring an indefinite short circuit output condition. About the detailed protection function, see **Electrical Specifications** for "Short-circuit Protection".

## Thermal Shutdown

The AC/DC converters are equipped with thermal shutdown circuitry. If the internal temperature of the converter rises above the designed operating temperature, the OTP function will shut down the unit. When the internal temperature decreases below the threshold of the temperature setting, then the units will self-restart. See **Electrical Specifications** table for Over Temperature Protection.

## Output Over Voltage Protection

The output voltage is monitored by an OVP circuitry. If the output voltage or the voltage apply from external of the converter rises to a fault condition (pre-setting value), which could be damaging to the load circuitry, so the OVP circuitry will be triggered, the protect method defined in the datasheet.

Apply an external voltage to the Synchronous-Rectifier models may cause permanent damages on the module.

### Single output :

The converters will shut down if  $V_{out} > V_{out\ nominal} + 20\%$ . Because the single output converters have a trim function that allows users to adjust the output voltage  $\pm 5\%$  or  $\pm 10\%$ ; hence, the Output Over Voltage Protection is setting  $> 20\%$ , to avoid trim voltage influences OVP.

Output Voltage (typ.)	5.0V	12V	15V	24V	28V	48V
OVP Trip Value	6V	14.4V	18V	28.8V	33.6	57.6

### Trimming Output Voltage – for Single output models

Only the single output converters have a trim function that allows users to adjust the output voltage  $\pm 10\%$  for non-Brick and  $\pm 5\%$  for Brick, please refer to the trim table in every datasheet for details. Adjustments to the output voltage can be used with a simple fixed resistor as shown in Figures 3 and 4. A single fixed resistor can increase or decrease the output voltage depending on its connection. Resistors should be located close to the converter.

※ Trim adjustments higher than the specified range can have an adverse effect on the converter's performance and are not recommended.

Excessive voltage differences between output voltage and sense voltage, in conjunction with trim adjustment of the output voltage; can cause the OVP circuitry to activate.

Thermal de-rating is based on maximum output current and voltage at the converter's output pins. Use of the trim and sense functions can cause output voltages to increase, thereby increasing output power beyond the converter's specified rating. Therefore:  $(V_{out\ at\ pins}) \times (I_{out}) \leq \text{rated output power}$

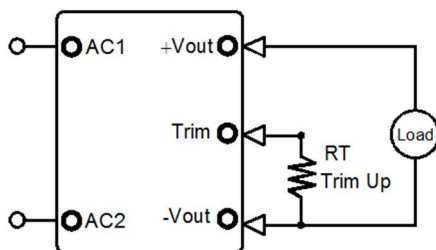

Figure 3. Trim up

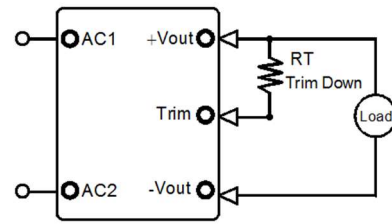

Figure 4. Trim down

### Remote Sense

Except for non-Brick series converters, all brick series converters employ the remote sense feature to provide point of use regulation, thereby overcoming moderate IR drops in pcb conductors or cabling. The Sense and VOUT lines are internally connected through low value resistors. Nevertheless, if the sense function is not used for remote regulation, the user should connect the +Sense to +VOUT and -Sense to -VOUT via a ten ohm resistor at the AC-DC converter pins as shown in Figure 5(a) below.

The remote sense lines carry very little current and therefore require minimal cross-sectional-area conductors. The sense lines are used by the feedback control-loop to regulate the output. As such, they are not low impedance points and must be treated with care in layouts and cabling. Sense lines on a pcb should be run adjacent to dc signals, preferably ground. In cables and discrete wiring applications, twisted pair or other techniques should be implemented as shown in Figure 5(b) below.

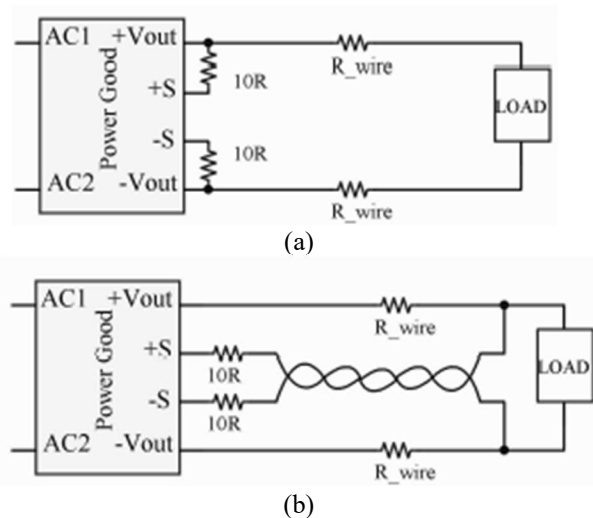

Figure 5. Remote Sense Circuit Configuration

All brick series converters will compensate for drops between the output voltage and the sense voltage at the AC-DC provided that:

$$[V_{out(+)} - V_{out(-)}] - [Sense(+) - Sense(-)] \leq 5\% V_{out}$$

## Minimax Output Load Requirement

All AC/DC converters regulate within spec and are stable under no-load to full load conditions. Operation under no-load and light load conditions, the burst mode function will increase the output ripple and noise.

## Floating Outputs

Since these are isolated AC/DC converters, their outputs are "floating" with respect to their input. Designers will normally use the -Vout as the ground/return of the load circuit. You can, however, use the +Vout as ground return to effectively reverse the output polarity.

## EMI Consideration

ACE25/60 AC/DC converters can meet Class B in EN 55032, CISPR 22 and FCC part 15J without external Filter. Except for ACE25/60 series, the conducted EMI measurement is recommended to use a simple extra circuit at input of AC/DC converters to meet the standard. For further details, please contact us.

## Connection in Parallel

There are two types of the parallel methods in our design, one is droop sharing and the other is natural current sharing.

### (1) Droop sharing

Only ACF700 series provide Droop sharing (also called droop control) that introduces a controlled voltage drop in each power module as its output current increases.

### (2) Natural current sharing.

A simple method of parallel connection is the use of an oring diode on each unit. See figure 8. By adjusting the outputs with Potentiometers, it is possible to achieve the current sharing of the units. The voltage rating of the external diodes must be greater than Vout. The current rating of external diodes should be greater than 2 times of each output.

The strength is that it's oring diode will become reversed biased and reduce the failure rate from affecting the bus voltage. This is the essential feature in a redundant power configuration. The weakness is the power loss in the diodes and dissipating the heat generated in the diodes. The loss is significant and should always be considered.

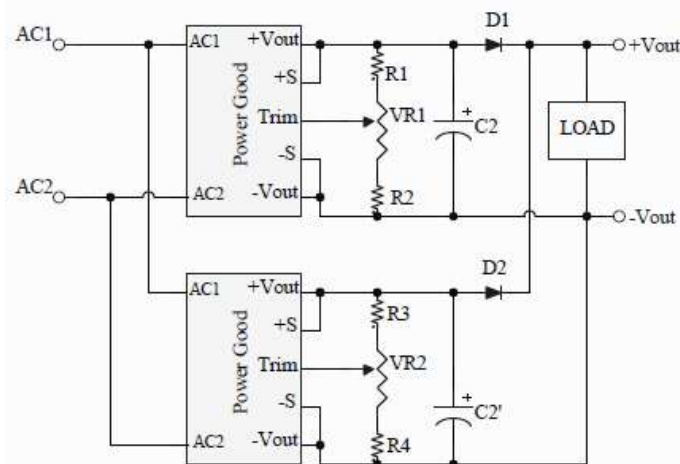

Figure 8. Connection in Parallel

## Connection in Series

Series operation connects the outputs of multiple power supplies in sequence so that the total output voltage equals the sum of the individual supply voltages, as shown in Figure 9. This configuration allows a single load or multiple loads to draw power from different voltage nodes. However, the output current in a series system must be limited to the lowest rated current among the supplies to prevent overload or equipment damage.

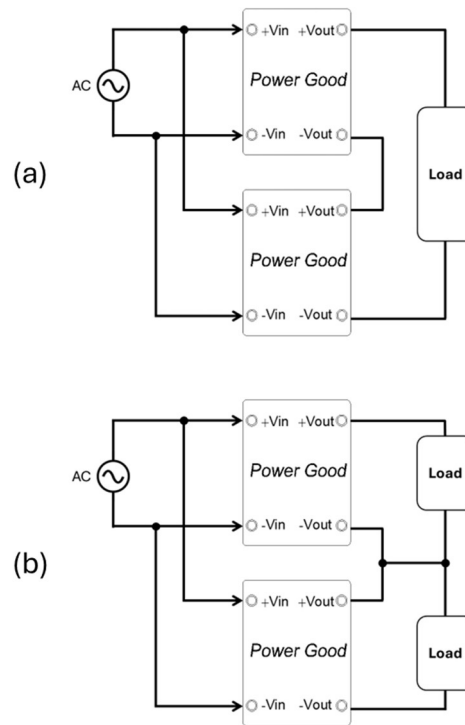

Figure 9. Redundant Connect

## Redundancy

As stated above, AC-DC Converters' connection in parallel is used to reduce the failure rate and further to improve the reliability of the system. An important thing is that it's not desirable to lift power. Because the output voltage of the AC-DC converters can't be completely equal, the converter with higher output voltage may provide full load current. It does not matter but make sure that the output current from each power supply does not exceed the rate current. See Figure 10.

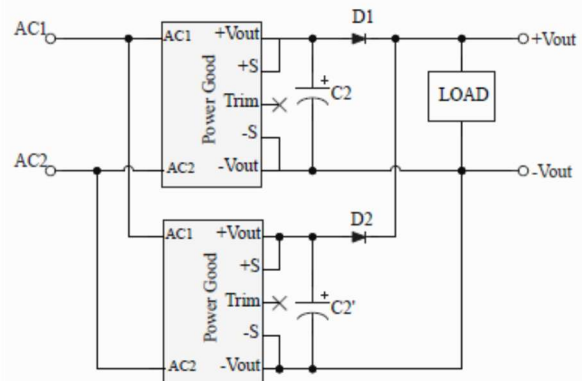

Figure 10. Redundant Connect

## Soldering Operation Recommendations

**Note1:** The IPC-A-610 standard requires that solder fill at least 75% of the barrel to ensure a solid connection. Ideally, all connections should have a 100% fill.

**Note2:** Hand-Soldering Guideline for Multi-layers PCB board  
400°C +/- 10 °C temperature on a 70W iron

(ø1mm) 400°C Soldering time <6S

(ø2mm) 400°C Soldering time <4S

**Note3:** Reflow soldering is not a suggested method for through-hole power modules due to many process and reliability concerns. If you have this kind of application requirement, please contact Power Good sales or FAE for further confirmation.